

Delivery Guidelines

Labeling

All materials must be identified with the following information:

- Company name and address
- Job number
- Campaign co-ordinator or sales manager
- Total quantity supplied
- Each delivery should contain stock consignment notes



Pallet Packing Requirements

- Pallets should be Australian standard size, 1165mm x 1165mm, and in good condition.
- Maximum height (including pallet) is 1324mm and the maximum weight of pallet must not exceed 1000kg.
- If using Chep, then Chep Transfer required. MMM do not exchange Chep Pallets.
- Do not mix different material types on the same pallet.
- The pallet should be wrapped in plastic or shrink wrapped for further protection. Strapping is also accepted.
- Outside edges should be vertically even and the cartons should be stacked so they do not protrude beyond the limits of the pallet. Cartons must arrive at MMM undamaged in any way.
- Each pallet and carton must be clearly labeled as detailed below

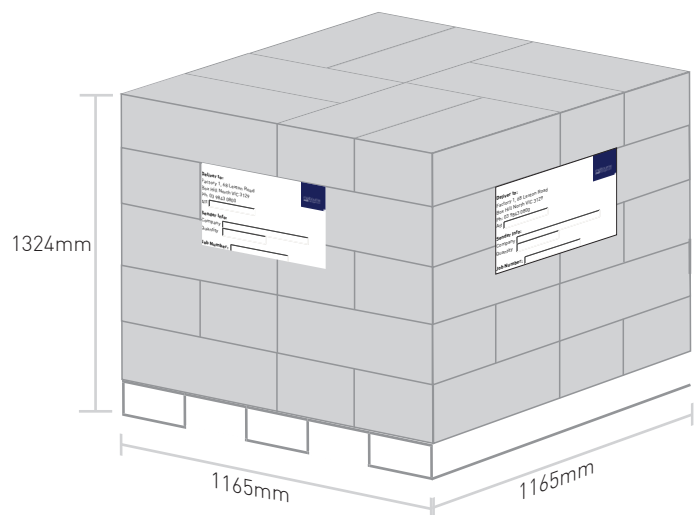

Other Information Required on Pallets

- Copies per bundle
- Bundles per pallet
- Total pallet quantity per delivery
- Pallet number

Delivery Address

- Address: Factory1/68 Lexton Rd, Box Hill North VIC 3129

Receiving Times

8.00 AM - 5.00 PM Mon - Friday

† Other times available, please contact your campaign co-ordinator.